

1/19/2012

BAL650C-4 *(also called BAL94C)*

Fluorescent Emergency Ballast

300-750 Lumens

- Works in conjunction with an AC ballast to convert new or existing fluorescent fixtures into unobtrusive emergency lighting
- Maintains illumination of one or two lamps in the emergency mode for a minimum of 90 minutes

Features

- Provides a minimum of 90 minutes of emergency illumination
- Can be installed inside, on top or in remote* of the fixture
- Can be used in both switched and unswitched fixtures
- UL 924 Listed for damp location
- UL listed for Retrofit/Field Installation
- Life safety NFPA 101
- NEC/OSHA
- Meets most state and local codes

Electrical

- Dual Voltage Input 120V/277 VAC, 60Hz
- Solid-state charger circuit
- Test Switch/Power Indicator light
- Temperature Rating (Ambient): 0°C to 50°C [32°F to 122°F]
- Maintenance-free, long life, Sealed Nickel Cadmium Battery
- Maximum battery recharge time: 24 hours

Housing

- Painted-white steel housing

Illumination

- Operates one or two lamps in the emergency mode for a minimum of 90 minutes – please refer to page 2 for more information. Provides a maximum initial lumen output of 750 Lumens

Project:	
Catalog#:	
Approved by:	



Lamp Compatibility

- Compatible with 1-lamp, 2-lamp, 3-lamp and 4-lamp fixtures with many ballast types including standard, rapid start, slimline, instant start, dimming and electronic AC ballast – consult factory regarding specific applications
- Compatible with many different lamp types – refer to back of page or contact customer service for more information

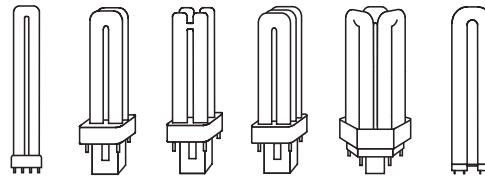

Dimensions

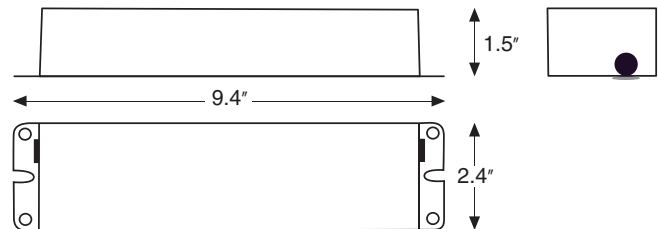

* Conditions apply for remote mounting. Check with the factory for more information.
Specifications subject to change without notice.



Emergency Ballast

Lamp Compatibility Data

Project:	
Catalog#:	
Approved by:	

Emergency Ballast

Ballast Model No.		No. Of Lamps Operated	BAL650C-2	BAL650C-4	BAL500	BAL700	BAL1400	BAL3000
Lumen Output			650	750	500	700	1400	3000
Linear Fluorescent Lamps	T8	1 Lamp	-	17-40	17-40	40-110	40-110	40-215
		2 Lamp	-	-	-	17-40	17-40	17-40
	T10	1 Lamp	-	17-40	17-40	-	-	-
		2 Lamp	-	-	-	17-40	17-40	17-40
	T12	1 Lamp	-	17-40	17-40	40-110	40-215	40-215
		2 Lamp	-	-	-	17-40	17-40	17-40
Compact Fluorescent Lamps	4-Pin CFL	1 Lamp	-	40-42	13-39	40-42	40-42	-
		2 Lamp	-	13-39	-	13-39	13-39	13-42
	4-Pin Long CFL	1 Lamp	-	40-42	13-39	40-50	40-50	40-55
		2 Lamp	-	18-40	-	18-40	18-40	18-40
	2-Pin CFL	1 Lamp	13-26	-	-	-	-	-
	T9 Circline CFL	1 Lamp	-	20	20-40	-	-	-
2 Lamp		-	-	-	20-40	20-40	20-40	
Special Fluorescent Lamps	U-Bent	T8						
		1 Lamp	-	32,40	32,40	-	-	-
	2 Lamp	-	-	-	32,40	32,40	32,40	
	T12	1 Lamp	-	32,40	34,40	-	-	-
2 Lamp		-	-	-	34,40	34,40	34,40	

In applications involving 2, 3, or 4-lamp instant start ballasts, for 2-lamp emergency operation, only 1 lamp will go dim in the test mode. When power is cut off to the fixtures, both lamps will come on (in EM Mode) as they are suppose to.

Specifications subject to change without notice.

Installation Instructions

When using this lighting device the safety precautions should be followed at all times.
PLEASE READ CAREFULLY AND FOLLOW ALL INSTRUCTIONS FOR YOUR OWN SAFETY

1. This device is designed for factory or field installation in either the ballast channel or on top of the fixture and can be used only with indoor fixtures. It is not suitable for use in air handling fixtures, near heated air outlets, or wet, and/or hazardous locations. Do not install this unit near gas or electric heaters.
2. Prior to installation the battery connection must be kept open to prevent high voltage potential across the yellow and red output leads. Do not assemble the battery connector until installation is complete and AC power is supplied to the emergency ballast.
3. This device is designed for use with one or two 6W-28W tubular fluorescent lamps with no integral starter; or one 13W-42W 4-pin compact fluorescent lamps with no integral starter; or two 13W-39W 4-pin compact fluorescent lamps with no integral starter.
4. All electrical connections must conform to the National Electric Code as well as all local regulations.
5. To reduce the risks of electric shock disconnect all normal and emergency power supplies including the battery connector before servicing.
6. An unswitched power source of 120 or 277 VAC, 60Hz is required for Battery Pack operation.
7. The unit has a sealed, no maintenance, Ni-Cad battery pack which is not replaceable in the field. Do not attempt to service the battery. Contact the manufacturer for information on service.
8. Use of any accessory equipment not recommended by the manufacturer may cause an unsafe condition.
9. This product should not be used for anything other than its intended use.
10. All service should be performed by qualified personnel.

Specifications subject to change without notice.

Installation Instructions

NOTE:All the branch circuit wiring has to be ready as well as an unswitched source of power before the fixture is installed. Confirm that the same branch circuit would be used for both the AC and Emergency ballasts.

CAUTION: Inverter connector has to be left open for preventing high voltage on the output leads (red and yellow). It has to be connected only after the installation process is completed and AC power is being supplied to the emergency ballast.

1. AC power has to be OFF before installation.
2. Choose the right wiring diagram to connect the emergency ballast to the AC ballast and lamp(s).
3. The emergency ballast can be used with one, two, three and four lamp fixtures and operates no more than 2 lamps in emergency mode. Study the wiring schematics carefully.
4. Follow diagram 1 to connect the emergency ballast and test plate. Please ensure that the electrical connections conform to the National Electrical Code and local regulations if applicable. Install the test plate close to the fixture or at a remote location within 50ft (recommended). The emergency ballast should either be installed at half the distance recommended by the AC ballast manufacturer (to install the AC ballast away from the lamps) or at a distance within 50ft, whichever is small. If there is no AC ballast then the emergency ballast needs to be mounted at a distance within 50ft.
5. The emergency ballast has to be connected to an unswitched 120VAC or 277VAC power source with no exception. Other voltages are not accepted. As mentioned before do not join the inverter connector until the fixture is completely installed and AC power is supplied continuously to the emergency ballast.
6. An additional unswitched hot wire (120VAC or 277VAC) has to be run to the junction box and connected to the emergency ballast in case of switched fixtures.
7. The battery needs to be charged for a minimum of two hours in order to do a short-term test of the emergency function. A full 24 hr charge is needed for a long-term emergency function testing.
8. Stick the additional CAUTION label that comes with the accessories' pack in a readily visible location. The label reads "CAUTION: This unit has more than one power supply connection point. To reduce risk of Electric shock, disconnect both the branch circuit breakers or fuses and emergency power supplies before servicing".

DIAGRAM 1

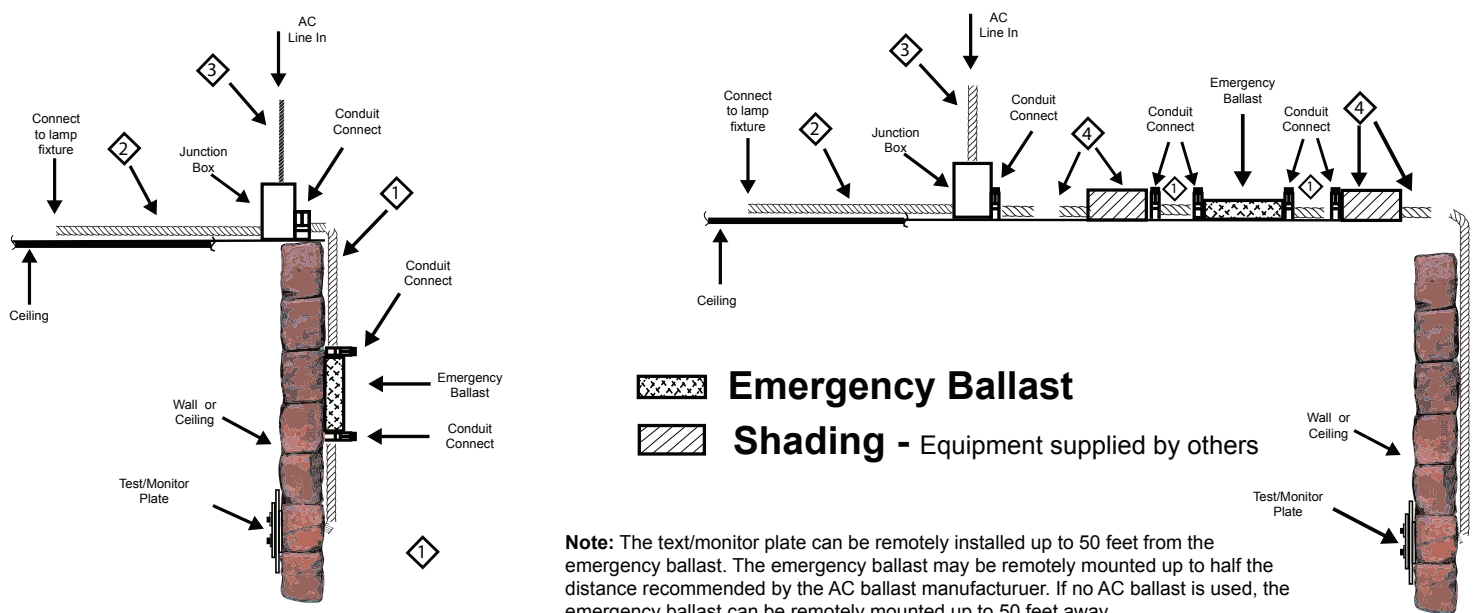

- ① - Flexible conduit (supplied) to connect ballast wire
- ② - Existing conduit to run existing wire to lamp holder (AC ballast on junction box). If AC ballast is on reflector, run yellow and blue wires from emergency ballast through this conduit
- ③ - AC line in
- ④ - Conduit and junction box (not supplied), necessary for remote installation

Specifications subject to change without notice.

Installation Instructions

OPERATION:

1. The charging indicator light would be ON to indicate that the battery is being charged when the AC power is supplied.
2. This Emergency ballast would function and operate one or two lamps at reduced illumination when the AC power supply is interrupted for a minimum of 90 minutes.

MAINTENANCE:

NOTE: Services should only be performed by qualified personnel. The emergency ballast should be checked periodically to confirm proper functionality and the following schedule is recommended by the manufacturer.

1. Inspect the charging indicator every month and confirm that it's illuminated.
2. Push the test switch for 30 seconds to ensure that the emergency ballast is functioning. Recommended to perform this testing once in every 30 days. Perform a long-term test (90-minute battery discharge) once in every 12 months and ensure that the lamp(s) are ON for a minimum of 90 minutes.

Wiring Diagrams

Note: Emergency Ballast and AC Ballast must be fed from the same branch circuit. Typical Schematics only, may be used with other ballasts, consult the factory for other wiring diagrams.

WIRE DIAGRAMS FOR 2-LAMP EMERGENCY OPERATION

Two-lamp emergency operation for lamps up to 39W

A. TWO (2) FOUR PIN COMPACT LAMP RAPID START BALLAST

1. B) FLEX Conduit Wiring Diagram:

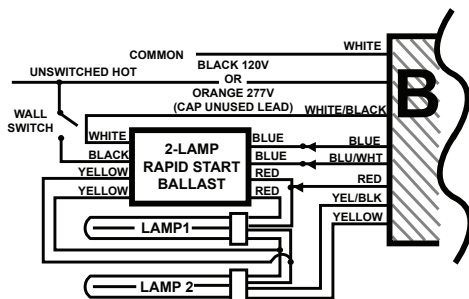

2. A) FLEX Conduit Wiring Diagram:

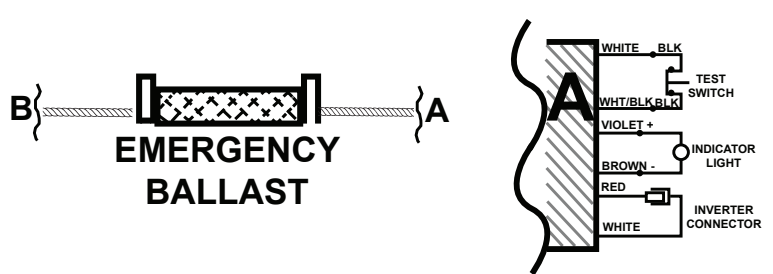

WIRE DIAGRAMS FOR 1-LAMP EMERGENCY OPERATION

B. TWO (2) LAMP RAPID START BALLAST

1. B) FLEX Conduit Wiring Diagram:

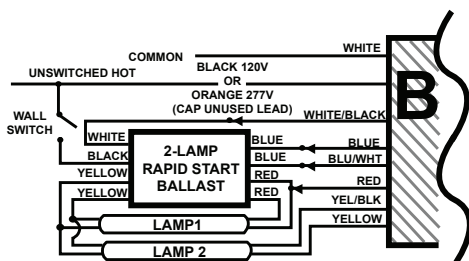

2. A) FLEX Conduit Wiring Diagram:

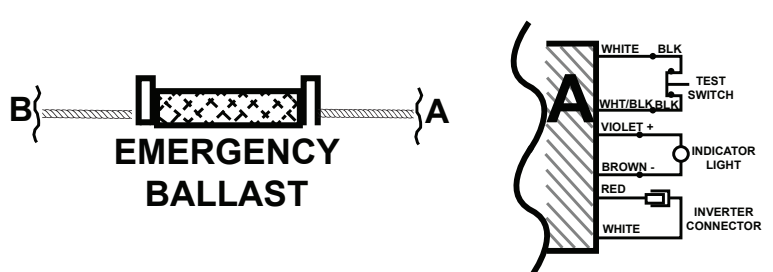

Specifications subject to change without notice.

Wiring Diagrams

Note: Emergency Ballast and AC Ballast must be fed from the same branch circuit. Typical Schematics only, may be used with other ballasts, consult the factory for other wiring diagrams.

WIRE DIAGRAMS FOR 1-LAMP EMERGENCY OPERATION

C. TWO (2) LAMP PREHEAT BALLAST *(Lamp 2 operates in emergency mode)*

1. B) FLEX Conduit Wiring Diagram:

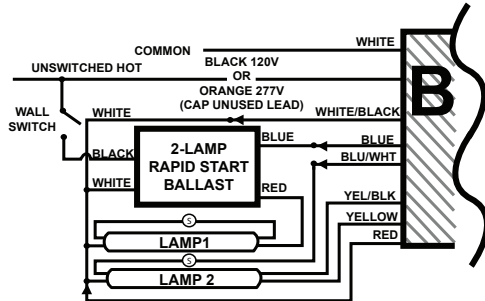

2. A) FLEX Conduit Wiring Diagram:

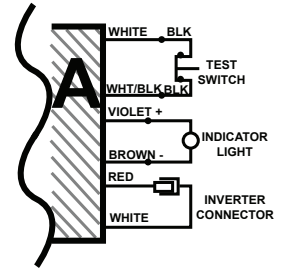

D. ONE (1) LAMP CHOKE BALLAST

1. B) FLEX Conduit Wiring Diagram:

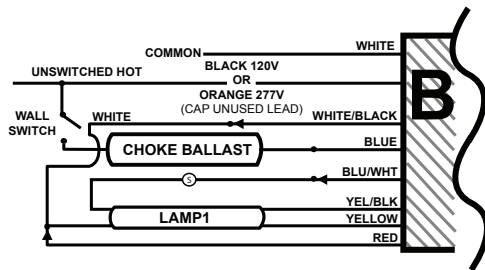

2. A) FLEX Conduit Wiring Diagram:

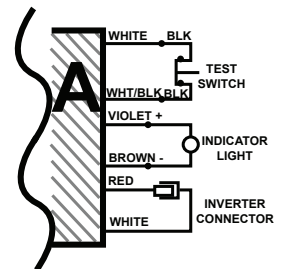

E. ONE (1) LAMP RAPID START BALLAST

1. B) FLEX Conduit Wiring Diagram:

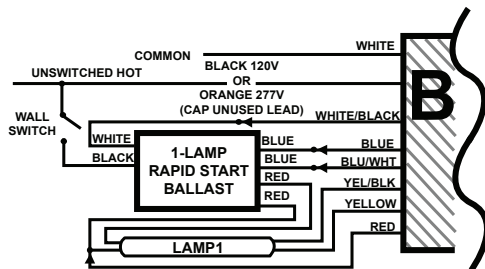

2. A) FLEX Conduit Wiring Diagram:

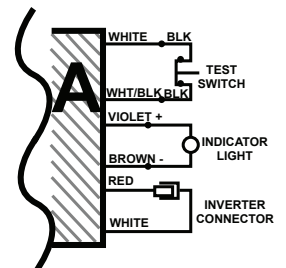

F. TWO (2) LAMP RAPID START BALLAST *(Lamp 2 operates in emergency mode)*

1. B) FLEX Conduit Wiring Diagram:

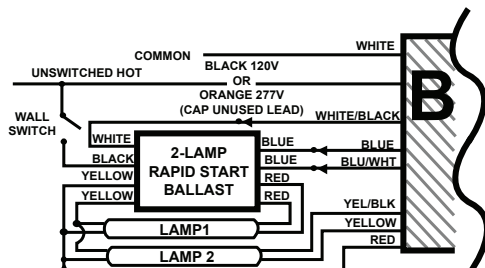

2. A) FLEX Conduit Wiring Diagram:

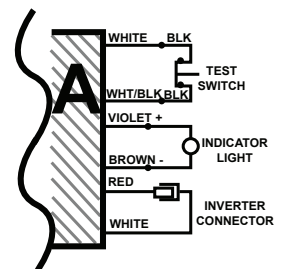

Specifications subject to change without notice.

Wiring Diagrams

Note: Emergency Ballast and AC Ballast must be fed from the same branch circuit. Typical Schematics only, may be used with other ballasts, consult the factory for other wiring diagrams.

WIRE DIAGRAMS FOR 1-LAMP EMERGENCY OPERATION

G. ONE (1) LAMP CIRCLINE RAPID START BALLAST

1. B) FLEX Conduit Wiring Diagram:

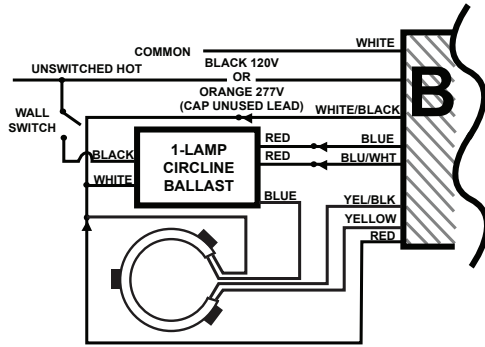

2. A) FLEX Conduit Wiring Diagram:

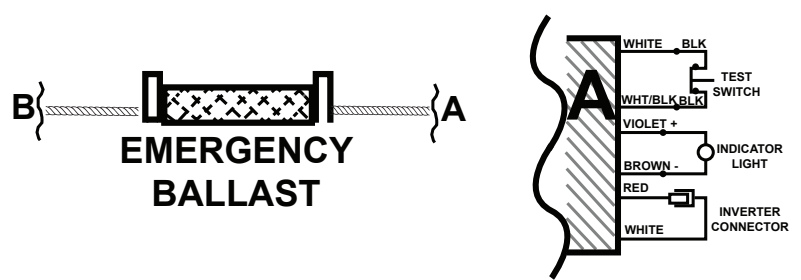

H. TWO (2) LAMP CIRCLINE RAPID START BALLAST (22 watt lamp operates in emergency mode)

1. B) FLEX Conduit Wiring Diagram:

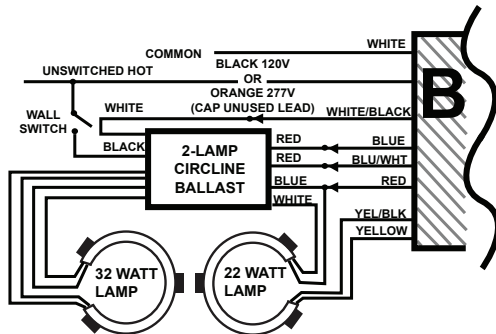

2. A) FLEX Conduit Wiring Diagram:

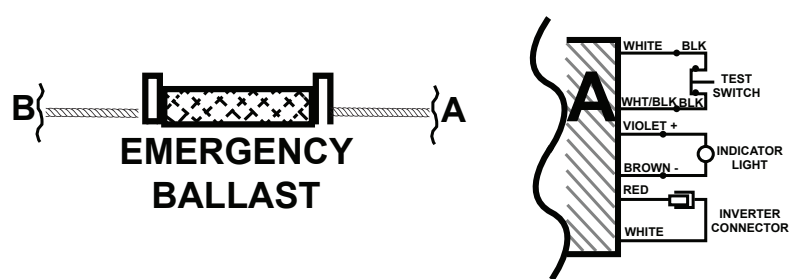

I. ONE (1) FOUR PIN COMPACT LAMP RAPID START BALLAST

1. B) FLEX Conduit Wiring Diagram:

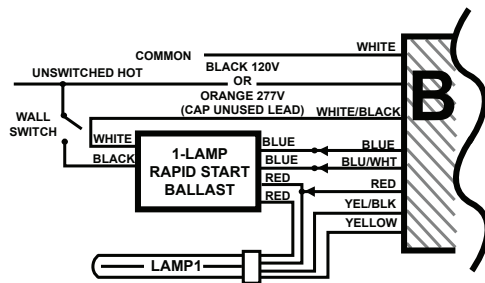

2. A) FLEX Conduit Wiring Diagram:

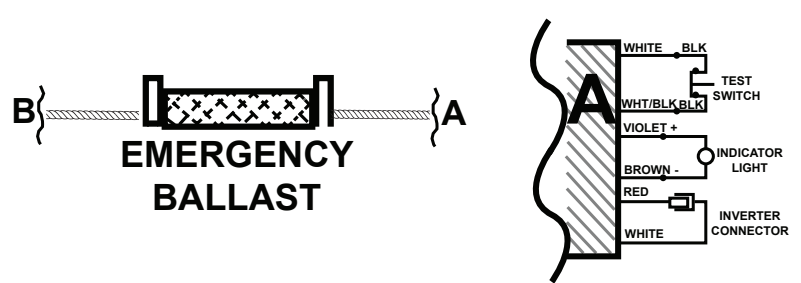

Specifications subject to change without notice.

Wiring Diagrams

Note: Emergency Ballast and AC Ballast must be fed from the same branch circuit. Typical Schematics only, may be used with other ballasts, consult the factory for other wiring diagrams.

WIRE DIAGRAMS FOR 1-LAMP EMERGENCY OPERATION

J. TWO (2) FOUR PIN COMPACT LAMP RAPID START BALLAST *(Lamp 2 operates in emergency mode)*

1. B) FLEX Conduit Wiring Diagram:

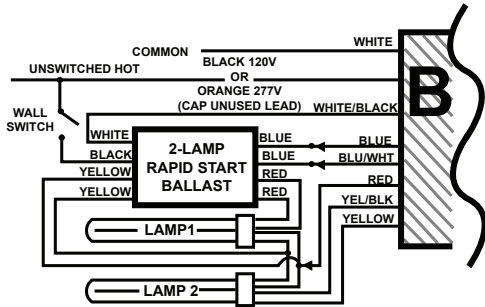

2. A) FLEX Conduit Wiring Diagram:

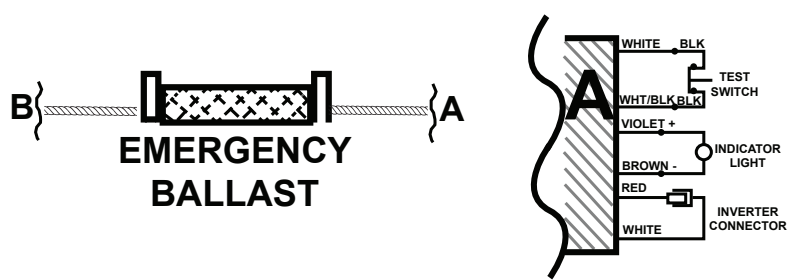

WIRE DIAGRAMS FOR EMERGENCY ONLY FIXTURES

K. ONE (1) LAMP WITHOUT AC BALLAST

1. B) FLEX Conduit Wiring Diagram:

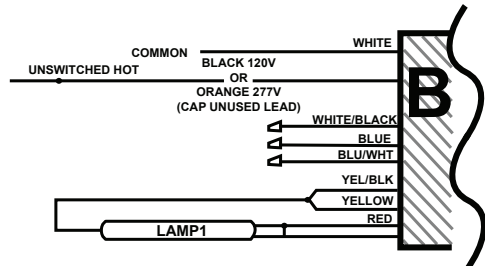

2. A) FLEX Conduit Wiring Diagram:

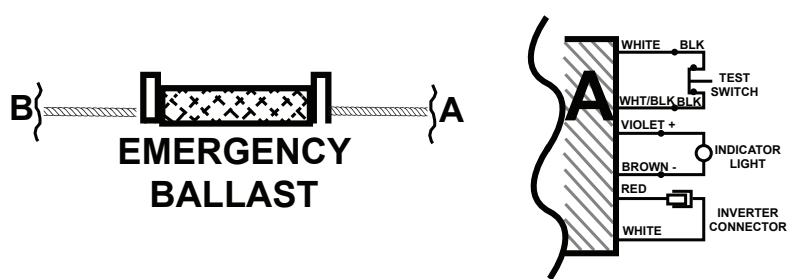

K. ONE (1) FOUR PIN COMPACT LAMP WITHOUT AC BALLAST

1. B) FLEX Conduit Wiring Diagram:

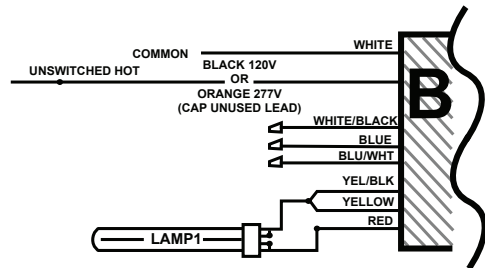

2. A) FLEX Conduit Wiring Diagram:

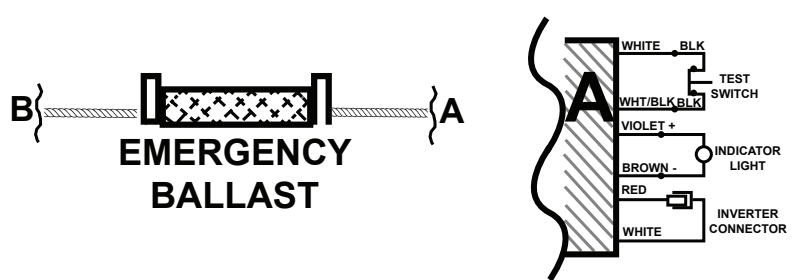

Specifications subject to change without notice.