



SPECIFICATION SHEET : FEP-210-600-L

This Is An Original Product From Fulham Co., Inc

Description : Sun Horse electronic ballast developed for use with UV & tanning lamp applications

This Ballast Will Operate Following Lamps.



F59T12H0(85W) / F72T12HO(100W) / F79T12HO(200W)

ELECTRICAL DATA (210V APPLICATION)

INPUT VOLT: 210V ± 10%, 50/60Hz									
LAMP WATTS/TYPE	F59T12HO 85W	F72T12HO 100W	F59T12HO 85W	F72T12HO 100W	F59T12HO 85W	F72T12HO 100W	F72T12VHO 160W	F79T12VHO 200W	F79T12VHO 200W
LAMPS OPERATED	4		3			2			1
INPUT WATTS	281.00	330.00	235.00	275.00	192.80	205.20	203.20	303	189.9
LINE CURRENT:	1.550	1.690	1.197	1.393	1.019	1.080	1.069	1.560	1.006
POWER FACTOR	0.926	0.933	0.933	0.938	0.900	0.905	0.906	0.928	0.900
BALLAST FACTOR	0.924	0.955	1.018	1.060	0.982	0.995	0.680	0.846	1.001
EFFICACY FACTOR	0.329	0.289	0.433	0.385	0.509	0.485	0.334	0.279	0.527
EMI/RFI COMPLIANCE	FCC PART 18-A								
SOUND RATING	" A "								
BALLAST TYPE	INSTANT START								
VOLTAGE TRANSIENTS	ANSI C82.11 - 1993 / C62.41								
THERMAL PROTECTION	AUTOMATIC RESETTING THERMAL SWITCH								
MIN. OPERATING TEMP	0 °C (32 °F)								
MAX. CASE TEMP	70 °C (158 °F)								
ENERGY STAR 4.0	-								
APPROVALS/CLASS	UL /cUL LISTED, CLASS " P ", 1 OUTDOOR								

MECHANICAL DATA

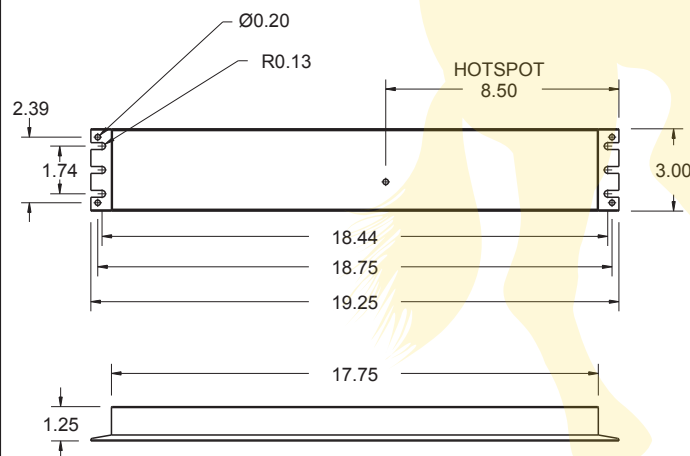

Where : L = Length, W = Width, H = Height

WIRING DIAGRAMS

WIRE	BLACK	WHITE	RED	BLUE	YELLOW	BROWN
LENGTH - INCHES	24 ± 1"	24 ± 1"	48 ± 1"		48 ± 1"	

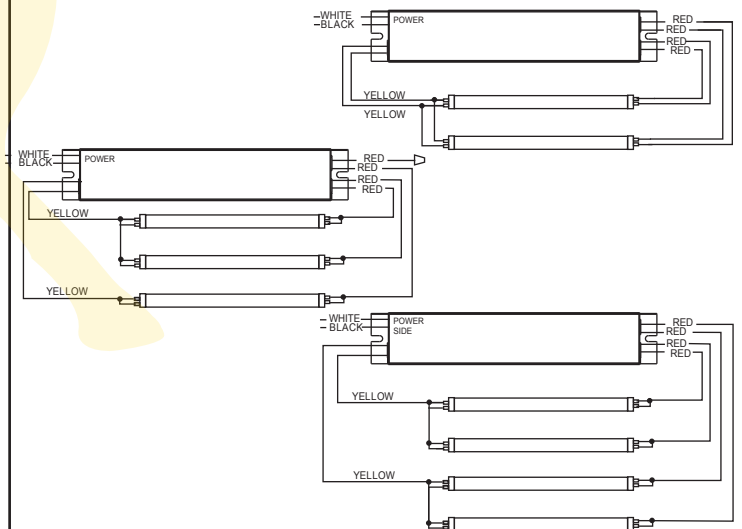

NOTE : This Ballast Case Must Be Grounded

Fulham Co., Inc extends limited warranty only to the original purchaser or to the first user for the period of **3 years** from the date of manufacture as indicated by the date code stamped on each product and when properly installed and under normal conditions of use. For additional warranty guide line, please refer to our complete product catalog or call customer service at 1-323-599-5000 DUE TO A PROGRAM OF CONTINUOUS IMPROVEMENT, FULHAM Co., INC RESERVES THE RIGHT TO MAKE ANY VARIATION IN DESIGN OR CONSTRUCTION TO THE EQUIPMENT DESCRIBED. Data is based upon tests performed by Fulham in a controlled environment and representative of relative performance. Actual performance can vary depending on operating conditions.
Address: 12705 S. Van Ness Ave., Hawthorne, CA 90250 **Website:** www.fulham.com **To order this product:** **Fax:** 1-323-754-9060 **Email:** order@fulham.com 2006-139 rev