

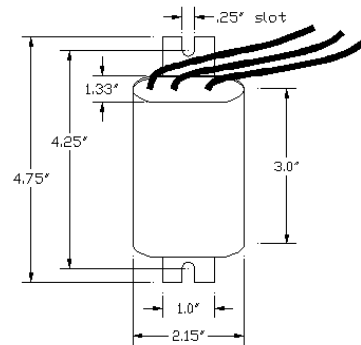

<b>Input Volts</b>		120	208	240	277
<b>Circuit Type</b>	PS-CWA				
<b>Power Factor</b>	0.95				
<b>Regulation</b>					
Line Volts	±10				
Lamp Watts	- 10 % + 10 %				
<b>Line Current (Amps)</b>					
Operating		7.21	3.89	3.62	3.13
Open Circuit		3.10	1.43	1.57	1.36
Starting		6.49	3.60	3.20	2.78
Recommended Fuse		15	9	8	7
<b>UL Temperature Ratings</b>					
Insulation Class	H(180°C)				
Coil Temperature Code		1029C	1029B	1029C	1029C
Benchtop Coil Rise Primary		82	66	74	76
Benchtop Coil Rise Secondary		84	76	83	84
<b>Input Watts</b>		827	814	819	820
<b>NOM Open Circuit Volts</b>	385				
<b>Current Crest Factor</b>	1.67				
<b>Input Voltage at Lamp Dropout</b>		60	105	120	153
<b>Min Ambient Starting Temp.</b>	-20°F -30°C				
<b>High Potential Test (Volts)</b>					
1 Minute	2000				
1 Second	2400				
<b>Open Circuit Voltage Test (Volts)</b>					
Open Circuit Voltage	345 - 425				
Input Current	min	2.65	1.20	1.35	1.15
	max	4.45	2.05	2.25	1.90
<b>Short Circuit Current Test (Amps)</b>					
Secondary Current	4.45 - 5.45				
Input Current	min	4.40	2.55	2.20	1.90
	max	7.35	4.25	3.70	3.20
<b>Core and Coil Specifications</b>					
Dimension A"	2.5				
Dimension B"	4.5				
Weight (lbs.)	16.13				
Lead Lengths (in)	12				
<b>Capacitor Specifications</b>					
Microfarads	24				
Volts (min.)	480				
	<b>Oval OIL Filled DRY Film</b>				
Case Size (in.)	1.75	Not Available			
Height ( in.)	3.88				
Temp Rating °C	90				
<b>Starter Specifications</b>					
Model Number	ST1003				
BTL	10				
Temp Rating °C	105				

Wiring Diagram

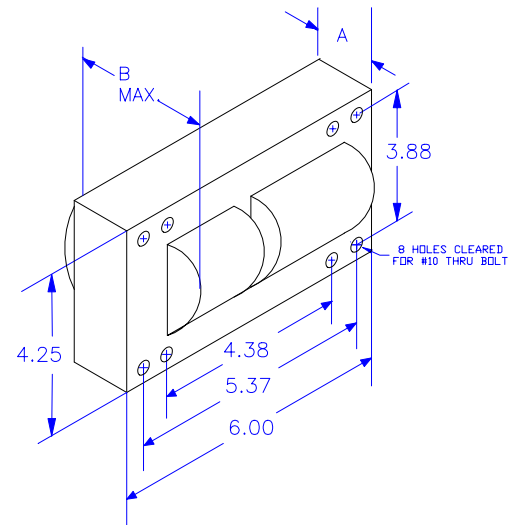
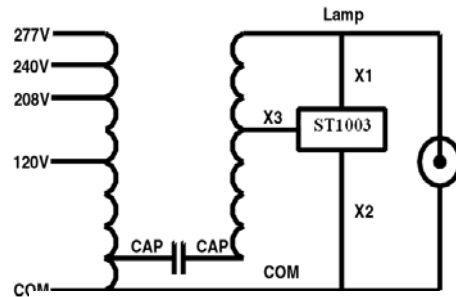

Specifications subject to change without notice.